

RODAN

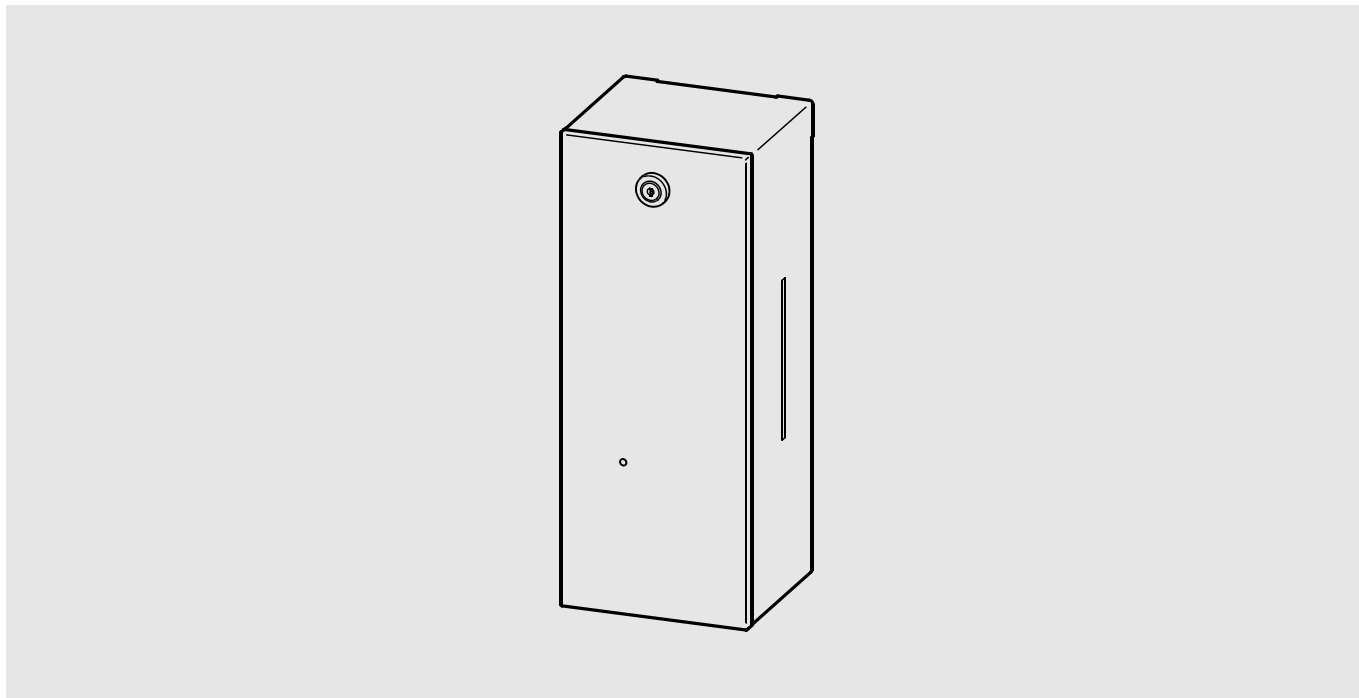

RODX625

2000090070

7612210067341

DE	Montage- und Betriebsanleitung	Seifenspender
EN	Installation and operating instructions	Soap Dispenser, WM
FR	Notice de montage et de mise en service	Distributeur de savon
ES	Instrucciones de montaje y servicio	Dispensador de jabón
IT	Istruzioni per il montaggio e l'uso	Distributore di sapone liquido a
NL	Montage- en bedrijfsinstructies	Zeepverdelers
PL	Instrukcja montażu i obsługi	Dozownik mydła
SV	Monterings- och driftinstruktion	Tvålbehållare
CS	Návod pro montáž a provoz	Dávkovač mýdla
FI	Asennus- ja käyttöohje	Saippua-annostelija
RU	Инструкция по монтажу и вводу в эксплуатацию	



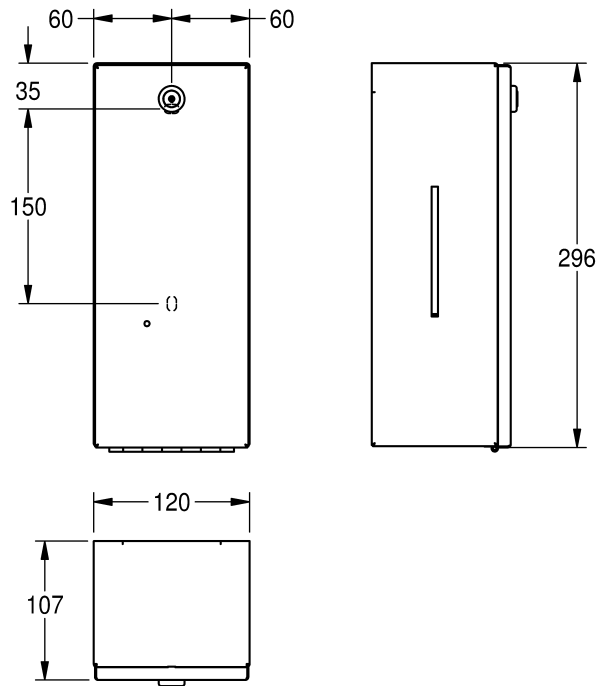
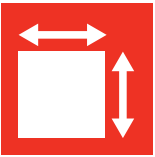
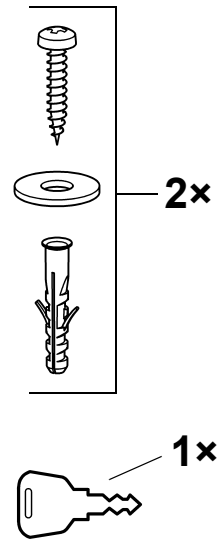
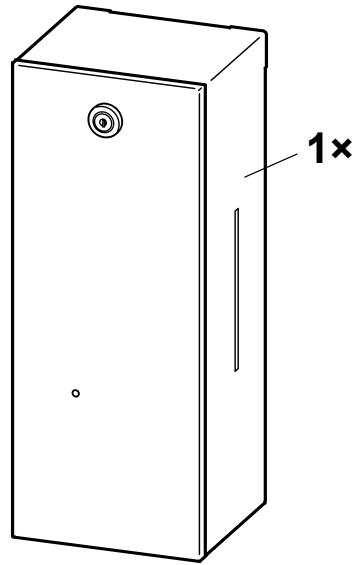

EN Installation and operating instructions

Important notes

- ▶ from factory: Not suitable for disinfectant soaps!
- ▶ Use only cream soap or liquid soap!
- ▶ Do not use any soaps with solid contents such as sand or granular material!
- ▶ Use only soaps with a viscosity of 0.01 to 35 dPa s!

Technical data

- ▶ Contents of soap tank 0.8 l
- ▶ Power supply Battery 4 × 1,5V AA

PL Instrukcja montażu i obsługi

Ważne wskazówki

- ▶ fabrycznie: Nie nadaje się do mydła do dezynfekcji!
- ▶ Stosować wyłącznie mydło w kremie lub płynie!
- ▶ Nie stosować mydła zawierającego ciała stałe jak piasek czy granulaty!
- ▶ Stosować wyłącznie mydła o lepkości od 0,01 do 35 dPa s!

Dane techniczne

- ▶ Pojemność zbiornika na mydło 0,8 l
- ▶ Zasilanie elektryczne Bateria 4 × 1,5V AA

FR Notice de montage et de mise en service

Remarques importantes

- ▶ ex usine: Ne se prête pas à des savons de désinfection !
- ▶ Utiliser uniquement du savon liquide ou sous forme de crème !
- ▶ Ne pas utiliser de savons contenant des matières solides telles que du sable ou des granulés !
- ▶ Utiliser uniquement des savons ayant une viscosité de 0,01 à 35 dPa s!

Données techniques

- ▶ Volume réservoir de savon 0,8 l
- ▶ Alimentation en tension Pile 4 × 1,5V AA

DE Montage- und Betriebsanleitung

Wichtige Hinweise

- ▶ ab Werk: Nicht für Desinfektionsseife geeignet!
- ▶ Nur reine Crem- oder Flüssigseife verwenden!
- ▶ Keine Seifen mit Feststoffanteilen wie Sand oder Granulat verwenden!
- ▶ Nur Seifen mit einer Viskosität von 0,01 bis 35 dPa s verwenden!

Technische Daten

- ▶ Inhalt Seifentank 0,8 l
- ▶ Spannungsversorgung Batterie 4 × 1,5V AA

SV Monterings- och driftinstruktion

Viktiga informationer

- ▶ från fabriken: Inte lämpad för desinfektionstvål!
- ▶ Använd bara ren krämtvål eller ren flytande tvål!
- ▶ Använd inte tvål som innehåller fasta partiklar som sand eller granulát!
- ▶ Använd endast tvål med viskositet mellan 0,01 och 35 dPa s!

Tekniska data

- ▶ Volym tvålbehållare 0,8 l
- ▶ Spänningsförsörjning Batteri 4 × 1,5V AA

CS Návod pro montáž a provoz

Důležité pokyny

- ▶ z továrny: Nevhodné pro dezinfekční mydla!
- ▶ Použijte výhradně jen krémové nebo kapalné mýdlo !
- ▶ Nepoužívejte mýdlo s obsahem pevných podílů, jako je písek nebo granulát !
- ▶ Používejte výhradně jen mýdla s viskozitou od 0,01 do 35 dPa*s !

Technické údaje

- ▶ Obsah nádrže na mýdlo 0,8 l
- ▶ Napájecí napětí 4 kusů baterií 1,5V AA

ES

Instrucciones de montaje y servicio

Indicaciones importantes

- ▶ desde fábrica: ¡No apto para jabones desinfectantes!
- ▶ ¡Utilizar únicamente jabón cremoso o líquido!
- ▶ ¡No utilizar jabones con componentes sólidos como arena o granulados!
- ▶ ¡Utilizar sólo jabones con una viscosidad de 0,01 a 35 dPa s!

Datos técnicos

- ▶ Contenido del depósito de jabón 0,8 l
- ▶ Alimentación de corriente Pila 4 × 1,5V AA

IT

Istruzioni per il montaggio e l'uso

Avvertenze importanti

- ▶ franco stabilimento: Non idoneo per saponi disinfettanti!
- ▶ Utilizzare solamente sapone puro in crema o liquido!
- ▶ Non utilizzare saponi con componenti solide tipo sabbia o granuli!
- ▶ Utilizzare solamente saponi con una viscosità dallo 0,01 ai 35 dPa s!

Specifiche tecniche

- ▶ Contenuto del distributore di sapone 0,8 l
- ▶ Alimentazione di tensione Batterie 4 × 1,5V AA

NL

Montage- en bedrijfsinstructies

Belangrijke aanwijzingen

- ▶ af fabriek: Niet geschikt voor desinfectiezeppen!
- ▶ Alleen crèmezeep of vloeibare zeep gebruiken!
- ▶ Geen zeep met vaste deeltjes zoals zand of granulaat gebruiken!
- ▶ Alleen zeep met een viscositeit van 0,01 tot 35 dPa s gebruiken!

Technische gegevens

- ▶ Inhoud zeepreservoir 0,8 l
- ▶ Voedingsspanning Batterij 4 × 1,5V AA

FI

Asennus- ja käyttöohje

Tärkeitä ohjeita

- ▶ noudettuna lähettäjältä: Ei soveltu desinfiointisaippuolle!
- ▶ Käytä vain voidemaista tai nestemäistä saippuaa!
- ▶ Älä käytä saippuaa joka sisältää kiinteitä ainesosia kuten hiekkaa tai rakeita!
- ▶ Käytä vain saippuaa jonka viskositeetti on 0,01 – 35 dPa s!

Tekniset tiedot

- ▶ Saippuasäiliön vetoisuus 0,8 l
- ▶ Jännitteensyöttö Paristo 4 × 1,5V AA

RU

Инструкция по монтажу и вводу в эксплуатацию

Важные указания

- ▶ С завода: Не предназначено для дезинфекционного мыла!
- ▶ Используйте только чистое кремовое или жидкое мыло!
- ▶ Не используйте мыло с содержанием твёрдых частиц, например песка или гранул!
- ▶ Используйте только мыло с вязкостью от 0,01 до 35 дПа*с!

Технические характеристики

- ▶ объём бачка для мыла 0,8 л
- ▶ напряжение питания 4 батарей x 1,5 В AA

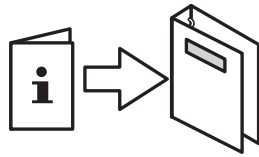
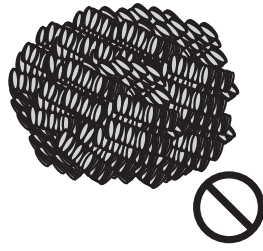

1. Montage

EN Installation
FR Montage
ES Montaje
IT Montaggio

NL Montage
PL Montaż
SV Montering

CS Montáž
FI Asennus
RU Монтаж

1

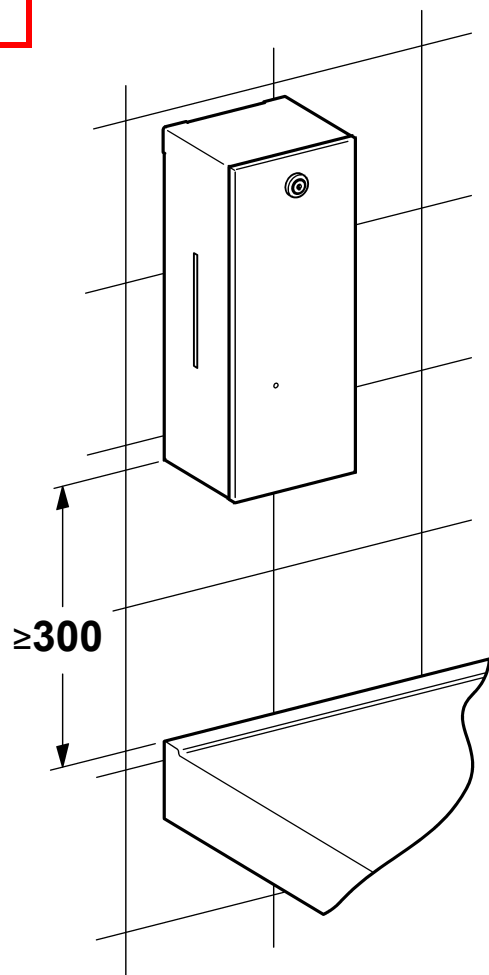

2

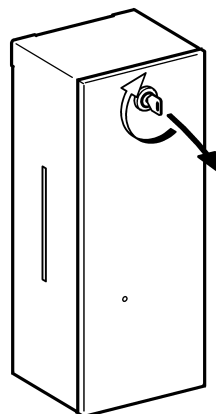

3

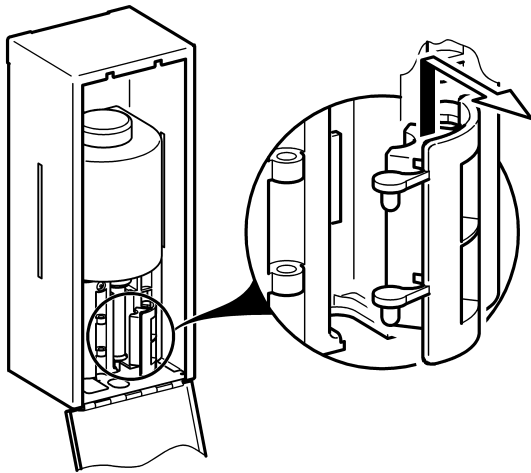

4

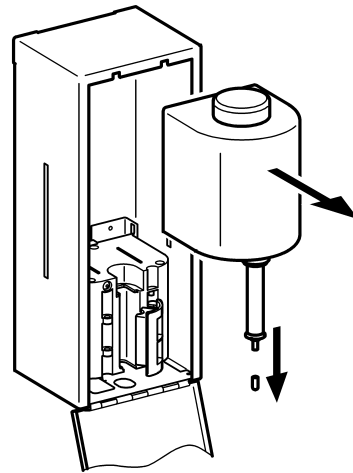

5

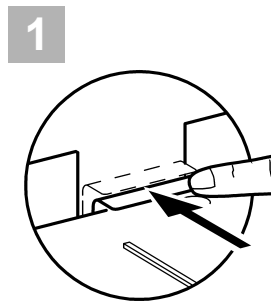
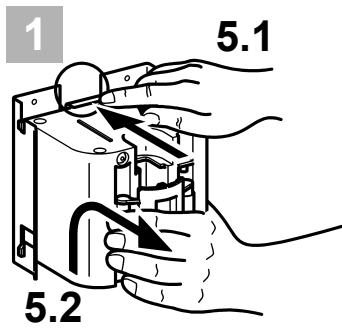

6

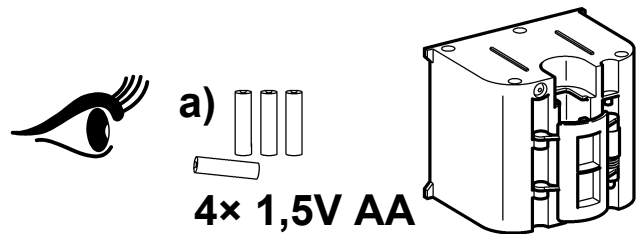
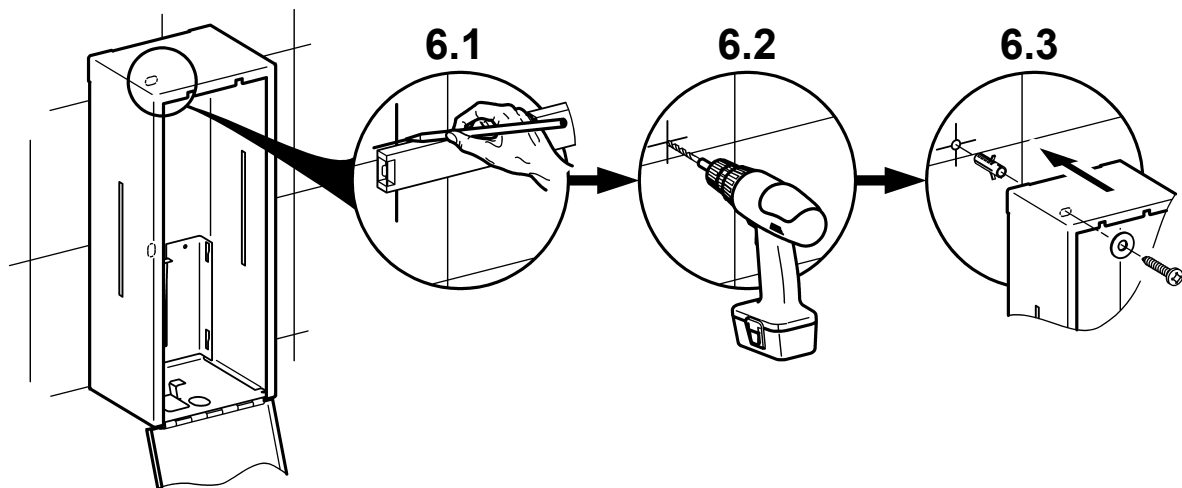

EN a) Not included in scope of delivery

DE a) nicht Lieferumfang

PL a) poza zakresem dostawy

SV a) ngår ej i leveransen

FR a) non compris dans la livraison

CS a) Není součástí dodávky

ES a) no forma parte del volúmen de suministro

FI a) ei kuulu toimitukseen

IT a) Non compreso nella fornitura

RU a) Не входит в объём поставки

NL a) niet bij levering inbegrepen

2. Wartung

EN Maintenance
FR Maintenance
ES Mantenimiento
IT Manutenzione

NL Onderhoud
PL Konserwacja
SV Underhåll

CS Varování
FI Huolto
RU Техническое обслуживание



4.

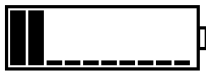
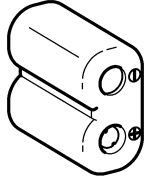

5.

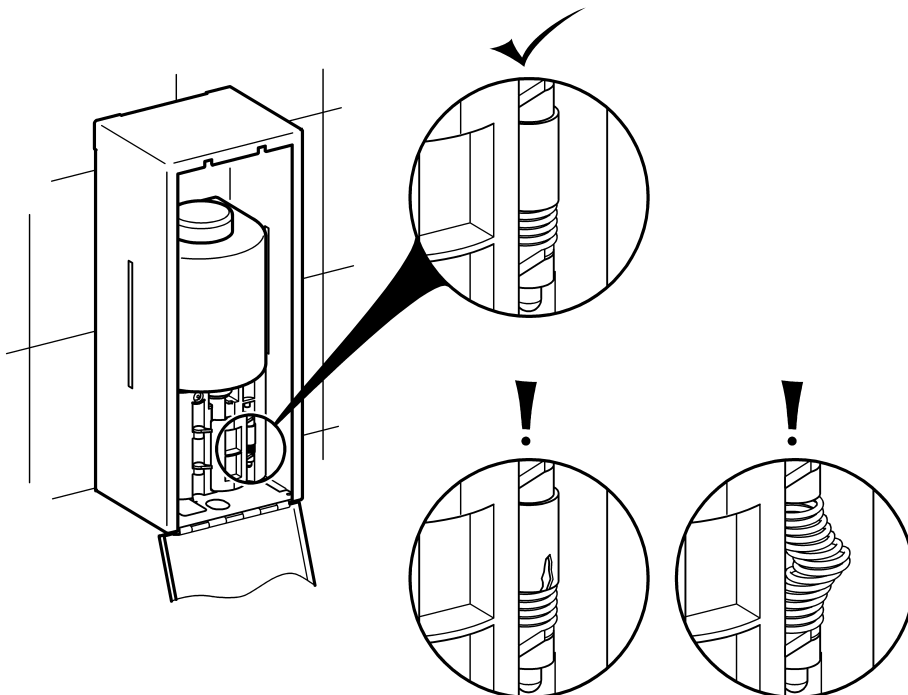
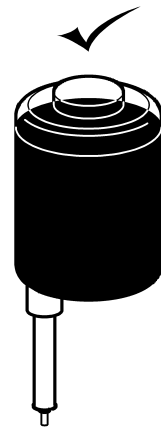
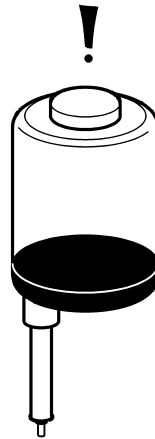

3. Batteriewechsel

EN Battery replacement
FR Remplacement des piles
ES Cambio de la pila
IT Cambio delle batterie

NL Batterijen vervangen
PL Wymiana baterii
SV Batteribyte

CS Výměna baterie
FI Paristonvaihto
RU замена батареи

1

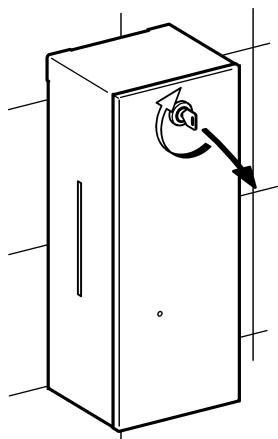

2

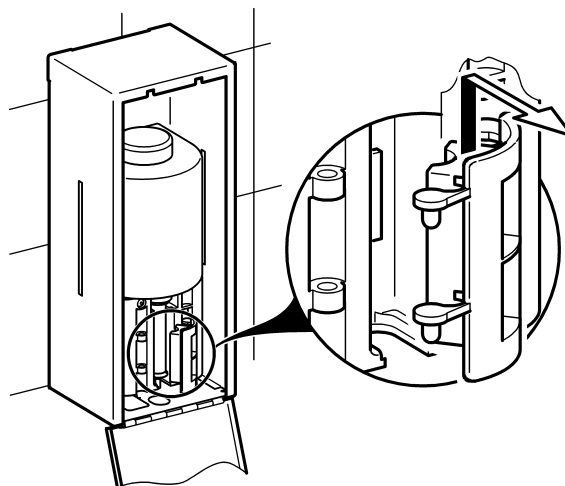

3

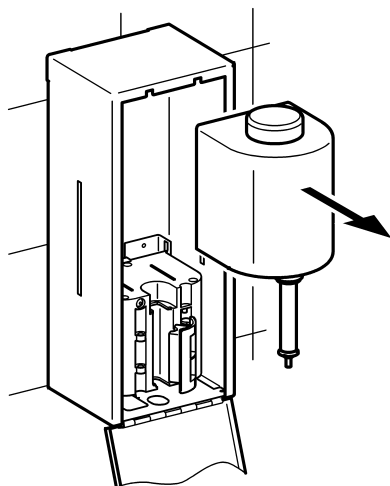

4

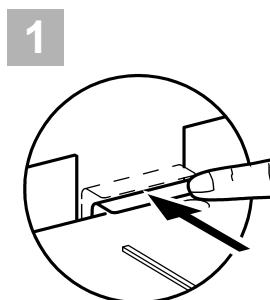
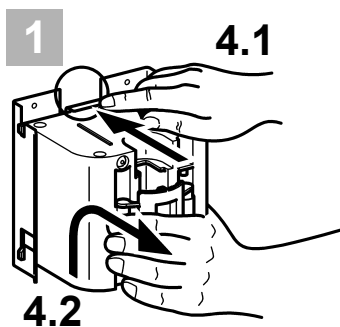

5

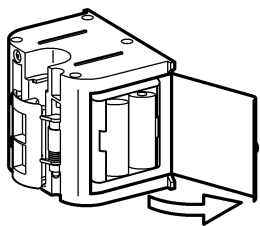

6

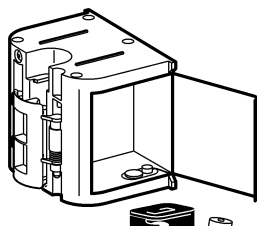

+/-



4× 1,5V AA

7

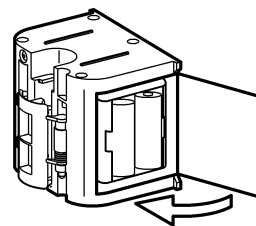

8

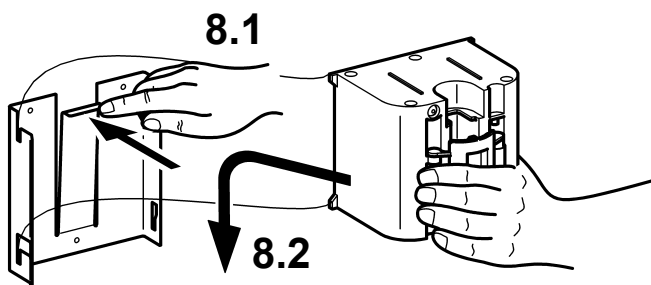

9

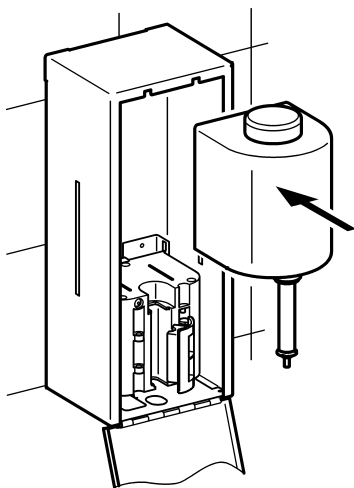

10

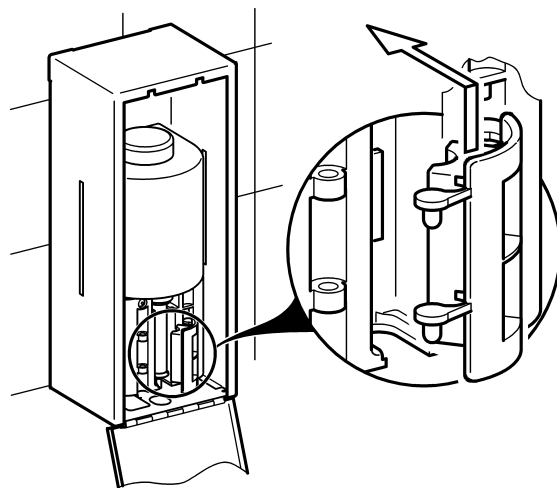

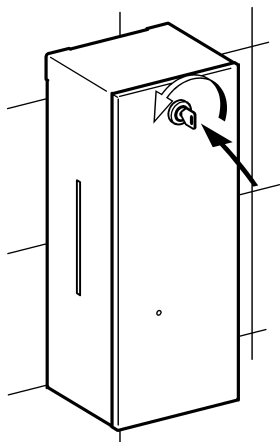
11

4. Tank füllen

EN Fill tank
 FR Remplir réservoir
 ES llenar la cisterna
 IT Riempire il serbatoio

NL Tank vullen
 PL Napełnić zbiornik
 SV Påfyllning av tanken

CS Plnit nádrž
 FI Tankin täyttäminen
 RU заполнить бак

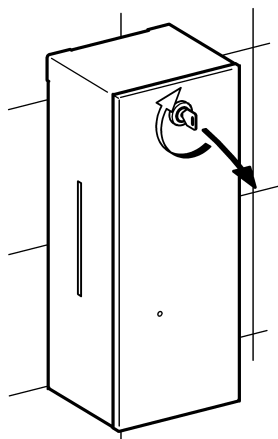
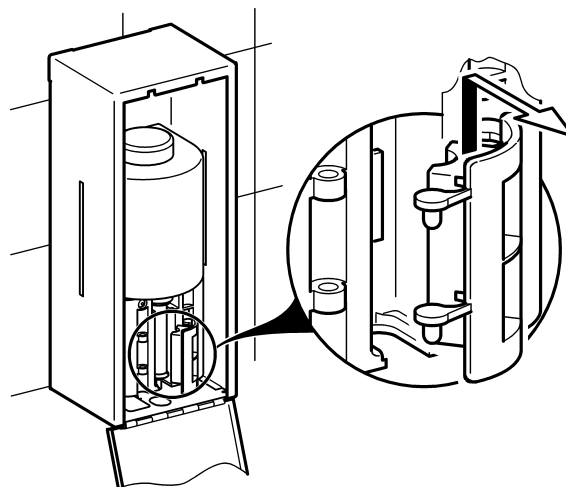
1**2**

3

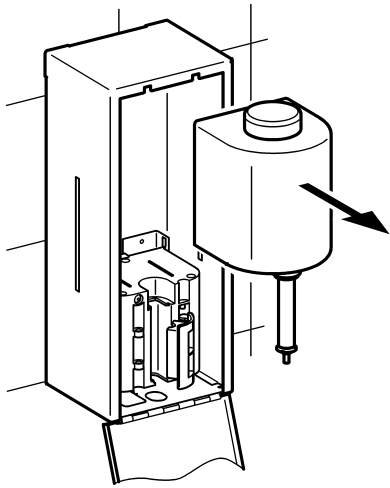

4

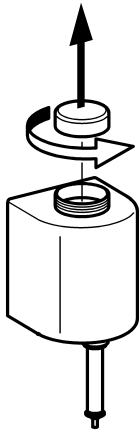

5

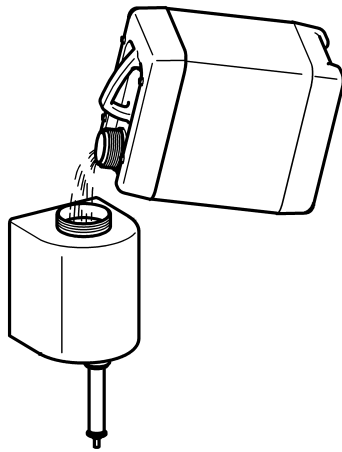

6

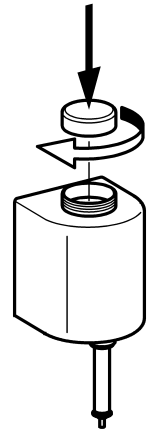

7

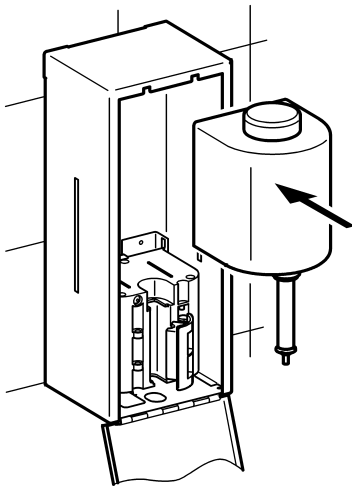

8

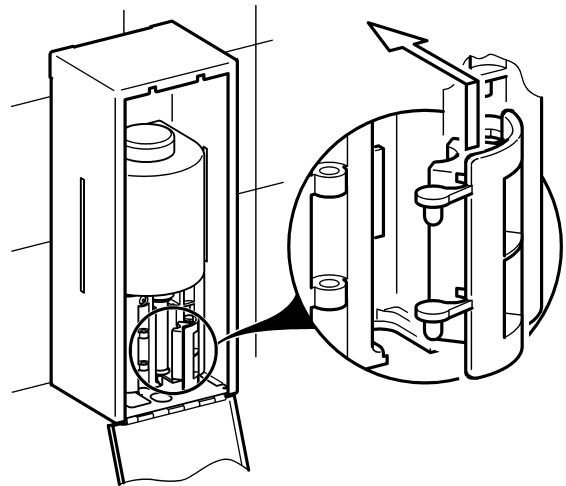

9

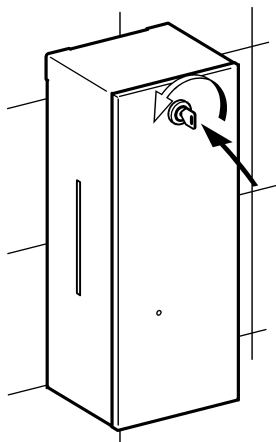

5. Ersatzteile

EN Replacement parts
FR Pièces de rechange
ES Piezas de recambio
IT Pezzi di ricambio

NL Reserveonderdelen
PL Części zamienne
SV Reservdelar

CS Náhradní díly
FI Varaosat
RU Запчасти

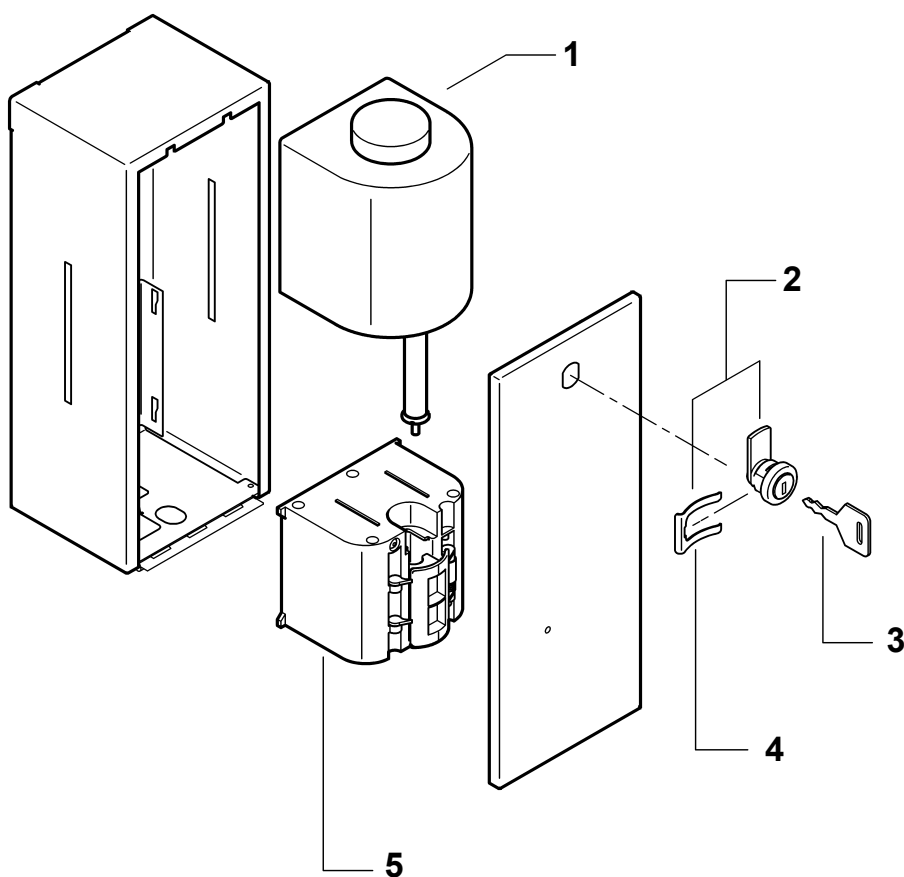

- 1.....2000103312
EACCS044
- 2.....2000103362
EACCS011
- 3.....2000103305
EACCS010
- 4.....2000103256
EACCS001
- 5.....2030006483
ERODX0001

6. Zubehör

EN Accessories
FR Accessoire
ES Accesorios
IT Accessori

NL Toebehoren
PL Akcesoria
SV Tillbehör

CS Příslušenství
FI Lisävarusteet
RU принадлежности

1



2



1.....2000103333 a)
EACCS055
22000057168
SO10L

EN a) Suitable for disinfectant soaps!

DE a) Für Desinfektionsseife geeignet!

NL a) Geschikt voor desinfectiezepen!

SV a) Lämpad för desinfektionstvål!

IT a) Idoneo per saponi disinfettanti!

RU a) Предназначено для дезинфекционного мыла!

FR a) Se prête à des savons de désinfection !

ES a) ¡Apto para jabones desinfectantes!

PL a) Odpowiednie do mydła do dezynfekcji!

FI a) Soveltuu desinfiointisaippuille!

CS a) Vhodné pro desinfekční mýdla!

Australia

PR Kitchen and
Water Systems Pty Ltd
Dandenong South VIC 3175
Phone +61 3 9700 9100

Austria

KWC Austria GmbH
6971 Hard
Phone +43 5574 6735 0

**Belgium, Netherlands &
Luxembourg**

KWC Aquarotter GmbH
9320 Aalst; Belgium
Phone +31 (0) 492 728 224

Czech Republic

KWC Aquarotter GmbH
14974 Ludwigsfelde, Germany
Phone +420 281 090 429

France

KWC Austria GmbH
6971 Hard
Phone +33 800 909 216

Germany

KWC Aquarotter GmbH
14974 Ludwigsfelde
Phone +49 3378 818 0

Italy

KWC Group AG
5726 Unterkulm, Switzerland
Numero Verde 800 789 233

Middle East

KWC ME LLC Ras Al Khaimah,
United Arab Emirates
Phone +971 7 2034 700

Poland

KWC Aquarotter GmbH
14974 Ludwigsfelde, Germany
Phone +48 58 35 19 700

**South Africa &
Sub Saharan Africa**

Franke South Africa
4052 Durban
Phone +27 31 450 63 00

Spain

KWC Austria GmbH
6971 Hard, Austria
Phone +43 5574 6735 211

Switzerland & Liechtenstein

KWC Group AG
5726 Unterkulm, Switzerland
Phone +41 62 768 69 00

Turkey

KWC ME LLC Ras Al Khaimah,
United Arab Emirates
Phone +971 7 2034 700

United Kingdom

KWC DVS Ltd - Northern Office
Barlborough S43 4PZ
Phone +44 1246 450 255

KWC DVS Ltd - Southern Office
Paignton TQ4 7TW
Phone +44 1803 529 021

EAST EUROPE

Bosnia Herzegovina
Bulgaria | Croatia
Hungary | Latvia
Lithuania | Romania
Russia | Serbia | Slovakia
Slovenia | Ukraine

KWC Aquarotter GmbH
14974 Ludwigsfelde, Germany
Phone +49 3378 818 261

SCANDINAVIA & ESTONIA

Finland | Sweden | Norway
Denmark | Estonia

KWC Nordics Oy
76850 Naarajärvi, Finland
Phone +358 15 34 111

OTHER COUNTRIES

KWC Austria GmbH
6971 Hard, Austria
Phone +43 5574 6735 0

